



HF05-0001 GSG 6 F M-SMP 050

Contacting PCBs GSG

NEW

Centers (mm/mil)	5,00 / 197
Current (Circular)	0,5 A
Current (Internal)	0,1 A
Impedance [Z]	50 Ohm
Frequency	6 GHz
Temperature	-20°C...+80°C

Spring Force (cN ±20%)

	Preload	Nominal
Total	-	430
Internal Cont.	-	-
Pins		
Circular Cont.	65	80
Core		
Circular Cont.	240	270

Travel (mm)

	Nominal	Maximum
Circular Cont. Tips	0,5	0,8
Circular Cont. Body	0,5	3,0
Thread	-	-
Wrench Size		3,2

Materials and Plating

Internal Cont.	BeCu, gold plated
Circular Cont.	BeCu, gold plated
Barrel	Brass, gold plated
Spring Tip Circular Cont.	Stainless steel, gold plated
Spring Circular Cont.	Stainless steel, unplated



PCB-GSG in Center 0,5 mm

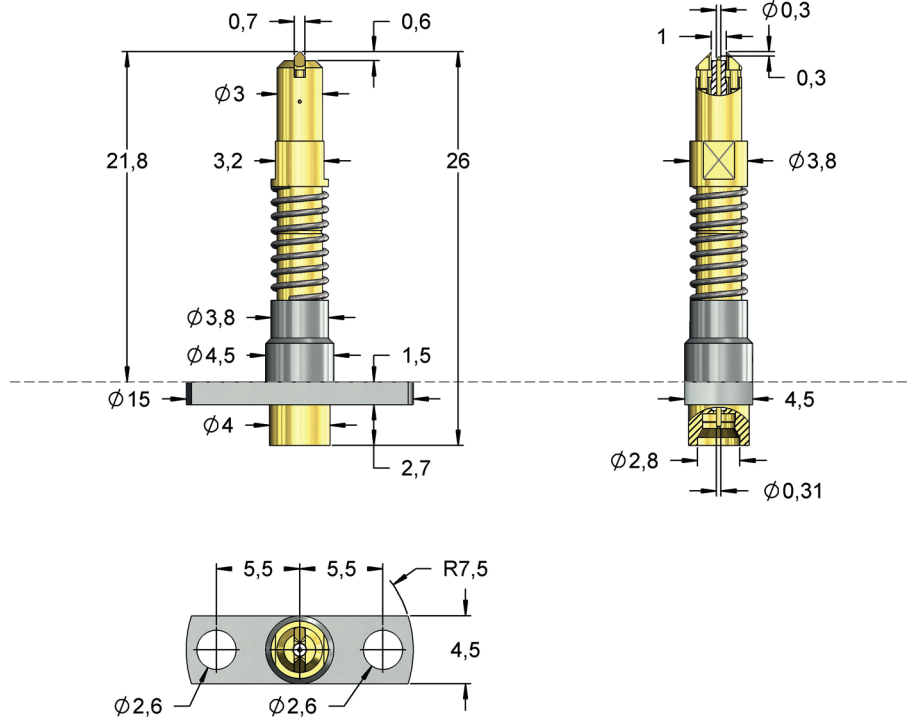

The probe can be mounted using the flange. For ensuring a correct alignment the probe is twist proof mounted in the flange. This probe design does not allow a wobble function of the probe. Cable connection with standard connector Mini SMP female.

RADIO FREQUENCY PERFORMANCE

Typical insertion loss	DC up to 3 GHz	3 GHz up to 6 GHz
Maximum	0,6 dB	1,0 dB
Typical return loss	DC up to 3 GHz	3 GHz up to 6 GHz
Minimum	14 dB	14 dB

This table shows the reference values in the middle and at the end of the recommended frequency.

Order Code	Description	Sensepin	Tip Style	Ø A	Ø B	C	H	L	Version
HF05-0001	HF05-0001 GSG 6 F M-SMP 050		03	0,30	3,00	-0,30	23,30	28,00	-



Mounting of the new RF series

Mounting Options

For the new RF probe series HF66 and HF05 different mounting options are possible.

Some probes can be threaded directly into the mounting plate.

Some versions have a flange that is screwed to the mounting plate, this version allows a simple adjusting and contacting of the DUT. The drill hole for mounting needs to have a sufficient diameter to allow a movement of the probe.

Mounting example 1

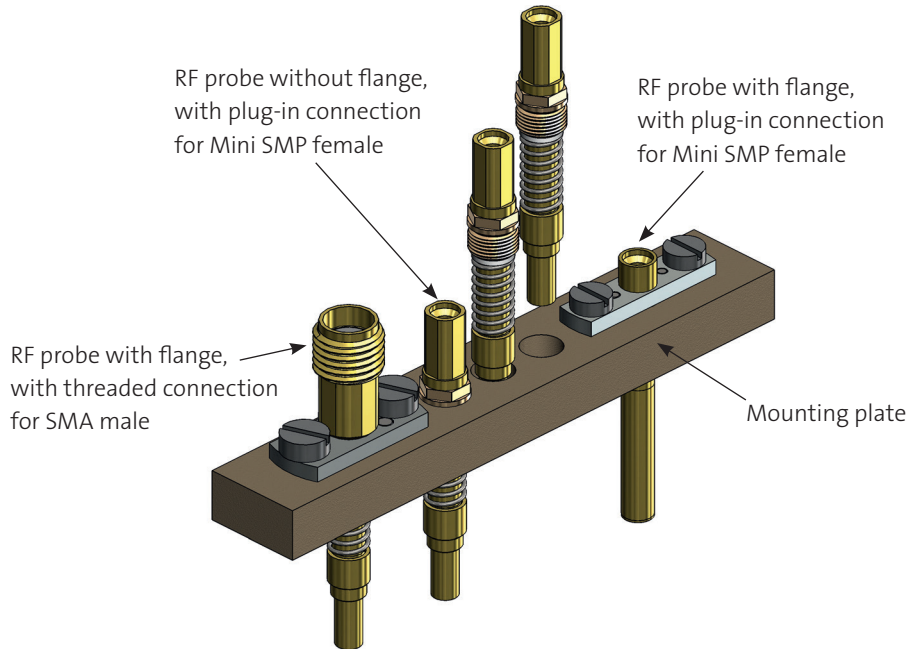

Mounting with Flange

For mounting RF probes with flange drill holes for the centering pins, threaded holes for the fixing screws as well as guiding holes for the probe are needed. These need to correspond with the pattern of the flange.

At first, the RF probe is inserted into the guiding hole and brought into the correct position with the alignment pins.

Afterwards the RF probe can be fixed with the screws.

The last step is the connection of the probe with a suitable connection cable. We recommend coaxial cables with low attenuation and low stiffness, because the cables move with the end of the probe when the probe is compressed and they need to allow a certain movement of the probes.

Mounting example 2

