



F67211B2008G020

Battery Contact for Direct Soldering on PCBs

Centers (mm/mil)	3,00 / 118
Current	5,0 A
R typ	<30 mOhm
Temperature	-45°C...+200°C (H)

With Bias Design

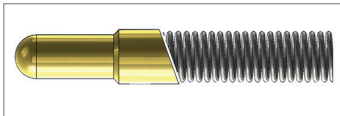

Spring Force (cN ±20%)

Version	Preload	Nominal
Standard	10	20

Travel (mm)

Version	Nominal	Maximum
Standard	0,6	1,0

Materials and Plating

Plunger	BeCu, gold plated
Barrel	Brass, gold plated
Spring	Stainless steel, unplated

Drill Size (mm)

Equal barrel-Ø	1,96 - 1,97
----------------	-------------

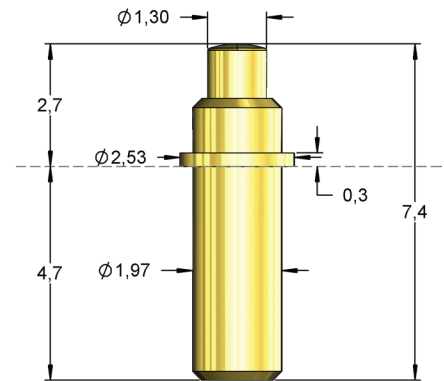

Solder Tight

F67211B0004G020 / F67211B0004G150

Battery Contact for Direct Soldering on PCBs with 20cN or 150cN

Centers (mm/mil)	3,18 / 125
Current	5,0 A
R typ	<30 mOhm
Temperature	-45°C...+200°C (H)

Design with drill hole plunger

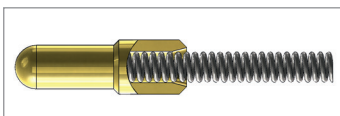

Spring Force (cN ±20%)

Version	Preload	Nominal
Standard	10	20
Standard	70	150

Travel (mm)

Version	Nominal	Maximum
Standard	1,0	2,8

Materials and Plating

Plunger	BeCu, gold plated
Barrel	Brass, gold plated
Spring	Stainless steel, unplated

Drill Size (mm)

Equal barrel-Ø	2,14 - 2,15
----------------	-------------

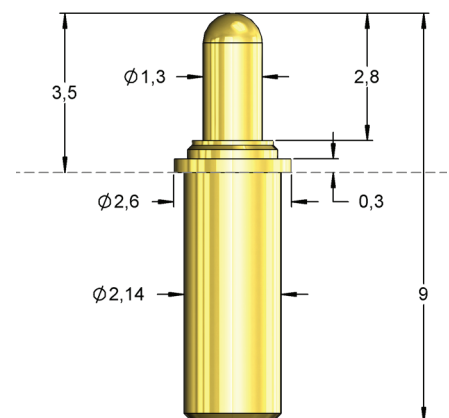

Solder Tight